

Specadie and Specadie Kit - User Instructions - 2I-03550-3



1. Introduction

The Specadie accessory allows for the production of a solid KBr pellet for analysis by Infra Red spectroscopy without the need of a separate press and die.

The Specadie consists of a die body and two bolts that each have a highly polished pressing face. In operation a ground KBr powder is placed in the die body and compressed between the two bolts that are tightened together. A KBr pellet of 8.5mm diameter is formed. The bolts are then removed and the compressed KBr powder is retained inside the die body. The die body in turn acts as the pellet holder and is placed into a spectrometer via the Specadie holder 3" x 2" mount plate P/N GS03560.

The Specadie can be provided as the die body, bolts and seal assembly only as P/N GS03550 or as a Kit of parts under P/N GS03700.

2. Unpacking and Checklist

On receipt of your Specadie accessory please ensure that the following have been supplied.

- 1 P/N GS03550 Specadie Accessory
- 1 P/N GS03560 Specadie holder 3" x 2" mount plate.
- 1 P/N GS03610 Bottle of KBr powder (50g).
- 1 P/N GS03595 Bench mounted spanner (wrench).
- 1 P/N GS03590 Pair of open ended spanners (wrenches) 9/16" and 1/2" AF. (1 only supplied with P/N GS03700).
- 1 P/N GS03570 Spare set of Specadie bolts.
- 1 P/N GS03580 Spare set of Specadie seals.

3. Specadie Care and Use with KBr Powder

The Specadie is made from corrosion resistant steel, but because of the corrosive nature of wet KBr or possibly from other substances used with the die, it is necessary to take certain precautions.

- A) When not in use always ensure that the die and its component parts are thoroughly clean and dry. If possible, it is preferable to store the die and components in a drying cabinet (Specacabinet P/N GS19100) or a desiccator.
- B) When cleaning the Specadie bolts polished faces pellets, do not use a cloth that has a hard abrasive texture. Always use a soft cloth or tissue. If KBr powder has been used as a sample for compression, any remaining powder should be washed away from the die body, bolts and seals with distilled water and then rinsed with methanol. After drying the parts with a soft cloth they can be placed on a warming plate to keep warm and dry until use with the next sample.

Note: KBr powder P/N GS03610 is supplied in a sealed glass bottle. The seal should not be broken until using the powder for the first time. Store the KBr powder in an oven at 50°C or a desiccator to prevent absorption of moisture.

4. Preparing the Specadie for Use

The Specadie and its component parts are packed at the factory in such a way that they do not suffer damage during transit. On receipt, remove the Specadie parts from their protective wrappings.

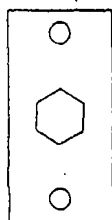

If you have received the Specadie Kit P/N GS03700, mount the bench spanner (see Figure 1) to a suitable surface where you will prepare the sample for use in the Specadie. The bench spanner is screwed or bolted to a work surface through the mounting holes at each end of the spanner.

◀◀◀ Figure 1 – Bench Spanner for Specadie.

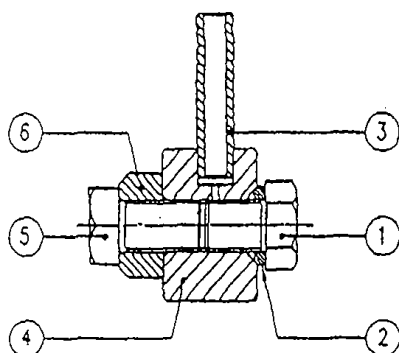

Figure 2 – Specadie Assembly

The Specadie body (4) (see Figure 2) and polished faces of the bolts will be lightly smeared with a silicone grease which must be removed before use. Wash all of the component parts of the Specadie thoroughly in an organic solvent (methanol) or a detergent to degrease the parts. Then ensure that the body is thoroughly dry by closing the ends of the body with your thumb and forefinger and connecting the evacuation tube (3) to a vacuum line for a minute or so.

Ensure that the short bolt (1) and the short bolt seal (2) are dry (having been wiped clean taking care to use non-abrasive cleaning cloths on the polished face of the bolt), then screw these parts into the Specadie body (4). Tighten the bolt (1) until the seal (2) has been compressed to approximately 75% of its thickness to ensure a vacuum tight seal.

5. Charging the Specadie with Sample

Insert the short bolt head (1) into the female hexagon cut out of the bench spanner. This will hold the Specadie body upright and prevent it from falling on its side which may result in spillage of sample.

Using a paper chute, funnel or spatula, pour a well ground mixture of KBr and sample into the Specadie aperture. (200mgs of mixture will make a pellet of about 2mm thick). Tap the side of the Specadie body (4) lightly so that the mixture is evenly distributed across the face of the short bolt (1) and that any surplus is shaken free from the internal screw threading of the Specadie body (4).

Screw the long bolt (5) with its seal (6) into the die body (4) as shown in Figure 2 until the seal is slightly compressed, forming a vacuum tight seal.

6. Making the Solid Pellet in the Specadie

To make the best quality pellets, the Specadie and its sample should be evacuated while pressing. Connect the evacuation tube (3) to a vacuum pump capable of 0.026 Torrs. It is recommended to warm the Specadie above room temperature.

Evacuate the Specadie from between 1 to 3 minutes depending on the dryness of the sample.

Now tighten the long bolt (6) with the 9/16" AF spanner provided until the sample is fully compressed.

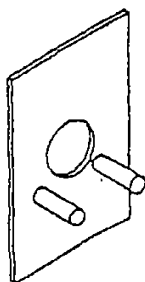

Maintain the vacuum during this tightening procedure and for a further 2 to 3 minutes thereafter. (If the bench spanner is unavailable, then two open-ended spanners are required to tighten the bolts together in the Specadie body).

Loosen the long bolt (5) and remove it from the die body (4). Then loosen and remove the short bolt (1) from the die body (4). A solid KBr disc suitable for spectroscopic study will now be formed in the die body (4). The die body (4) now serves as the pellet holder for the formed disc.

Insert the Specadie mount holder (see Figure 3) into the 3" x 2" slide mount holder of the spectrometer sample compartment and rest the Specadie body (4) on the two support rods of the mount holder.

Figure 3 – Specadie Mount Holder

After use the KBr pellet may be removed from the Specadie body (4) by washing under water from a running tap. Wait until the KBr pellet has completely dissolved and then rinse the body (4) with distilled water, then methanol and dry using the “vacuum, finger and thumb” procedure.

Wash and clean the bolts (1 and 5) and seals (2 and 6) and dry. When all of the Specadie components are dry it is ready to accept a new sample.

Note: *When not in use always ensure that the Specadie and its component parts are thoroughly clean and dry and if possible keep stored in a desiccator or drying cabinet (Specacabinet P/N GS19100). Do not wipe the polished faces of the bolts with cloths, which are of a hard, abrasive nature. Always use a soft cloth or tissue.*

7. Notes on Sample Pellet Quality

The quality of a pellet will depend largely on the KBr or KCl powder used, which should always be of a spectroscopic grade purity.

To ensure that a sample pellet is produced which will enable accurate spectra of samples to be obtained, it is essential that the sample be thoroughly blended with the halide salt powder. Blending can be achieved either by using a mortar and pestle (P/N GS03600) or by using a grinding mill such as the Specamill (P/N GS06000).

When the sample is added to the halide powder, the clarity of the disc will depend on the quantity and type of sample. Usually 0.1 to 2% of sample to KBr powder is quite adequate.

Generally, it is easy to produce a good quality pellet if the Specadie is used correctly. However, some faults in the produced sample pellet may occur due to a variety of reasons. Some of these faults and their remedies are tabulated below. The faults described are for pure KBr or other halide salts, which do not contaminate the sample. When the sample is added to the halide salt the clarity of the disc will depend to a large extent on the quantity and type of sample. Usually 0.1 to 2% of sample to KBr is perfectly adequate. The overall quality of a pellet is largely dependent upon the quality of the KBr or halide salt powder used, which should always be of a spectroscopic grade of purity.

Fault	Cause	Remedy
Sample pellet not clear. Lacks optical clarity.	Sample damp, contaminated KBr powder or insufficient pressure when compacting.	Dry the KBr powder or sample and increase the compacting pressure.
Sample pellet is clear but shows opaque spots.	Powder not uniformly flat in the die, leaving large particles which do not vitrify when pressed.	Sieve powder to extract coarse grains, then re-grind and re-press.
Sample pellet is cloudy.	Insufficient evacuation time or leaky seals.	Check seals on the die and lengthen evacuation period.
Sample pellet is clear at first but quickly becomes cloudy.	Damp powder or damp atmosphere.	Dry the KBr powder or sample, check seals on the die and lengthen evacuation period.

8. Legend

- 1 Short bolt.
- 2 Short bolt seal.
- 3 Evacuation tube.
- 4 Specadie body.
- 5 Long bolt.
- 6 Long bolt seal.

9. Spare Parts for the Specadie

- P/N GS03550 Specadie Accessory.
- P/N GS03700 Specadie Kit.
- P/N GS03570 Spare set of Specadie bolts.
- P/N GS03580 Spare set of Specadie seals.
- P/N GS03590 Pair of open ended spanners (wrenches) 9/16" and 1/2" AF.
- P/N GS03595 Bench mounted spanner (wrench).
- P/N GS03610 Bottle of KBr powder (50g).

Worldwide Distribution

France

Eurolabo - Paris.
Tel.01 42 08 01 28
Fax 01 42 08 13 65
email: contact@eurolabo.fr

Germany

L.O.T. - Oriel GmbH & Co,
KG - Darmstadt
Tel: 06151 88060
Fax: 06151 880689
email:info@LOT-Oriel.de
Website: www.LOT-Oriel.com/de

Japan

Systems Engineering Inc. -Tokyo
Tel: 03 3946 4993
Fax: 03 3946 4983
email:systems-eng@systems-eng.co.jp
Website: www.systems-eng.co.jp

Spain

Teknokroma S.Coop C. Ltda Barcelona
Tel: 93 674 8800
Fax: 93 675 2405
email: comercial@teknokroma.es

Switzerland

Portmann InstrumentsAG
Biel-Benken
Tel: 061 726 6555
Fax: 061 726 6550
email: info@portmann-instruments.ch
Website:www.portmann-instruments.ch

USA

SPECAC INC.

414 Commerce Drive
Suite 175,
Fort Washington,
PA 19034, USA
Tel: 215 793 4044
Fax: 215 793 4011

United Kingdom

Specac Ltd. - London
River House, 97 Cray Avenue,
Orpington
Kent BR5 4HE
Tel: +44 (0) 1689 873134
Fax: +44 (0) 1689 878527
Registered No. 1008689 England

www.Specac.com