

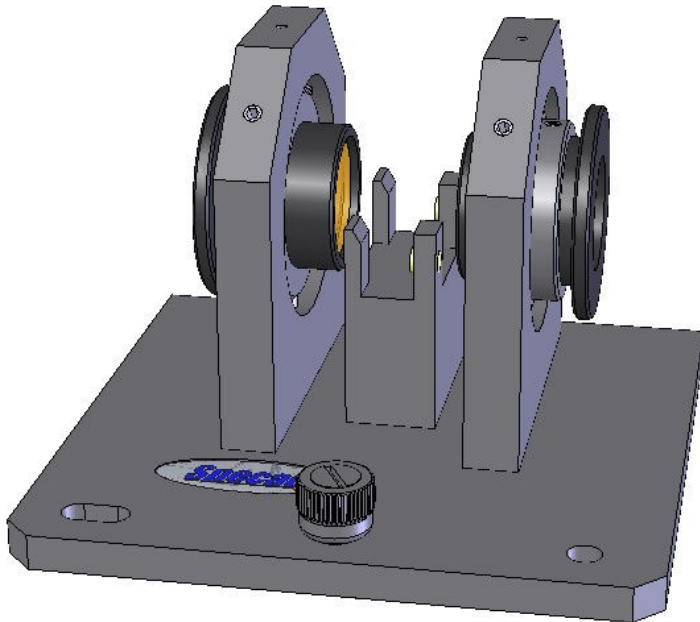

Microfocus Beam Condenser

User Manual



Microfocus Beam Condenser

User Manual

2I-02560 Issue 7

Microfocus Beam Condenser P/N's GS02560 and GS02561

MICROFOCUS BEAM CONDENSER

USER MANUAL

1. INTRODUCTION	5
2. UNPACKING AND CHECKLIST	6
3. WARNING FOR SAFE USAGE	7
CHEMICAL SAMPLES	8
4. USING THE MICROFOCUS BEAM CONDENSER	9
GENERAL PRINCIPLES	9
BENCHMARK™ BASEPLATE INSTALLATION	10
FITTING OF DC-3 IN THE MICROFOCUS BEAM CONDENSER	10
ALIGNMENT (LIGHT THROUGHPUT OPTIMISATION)	12
FOCUSING OF THE LENSES	13
ALIGNMENT PROCEDURE	16
OUTPUT LENS ADJUSTMENT	17
INPUT LENS ADJUSTMENT	17
CHANGE OF DETECTOR	18
NOTES ON CLEANING	18
5. CHANGING LENSES IN THE MICROFOCUS BEAM CONDENSER	23
6. SPARE PARTS - MICROFOCUS BEAM CONDENSER	24
7. LEGEND - BUBBLE PART NUMBER IDENTIFICATION	25

© April 2016 Specac Ltd. All rights reserved.

Brilliant Spectroscopy is a trademark of Specac Ltd.
Other product names mentioned herein may be trademarks
of their respective owners.

1. Introduction

Thank you for purchasing a Specac Product.

The Microfocus Beam Condenser is a precision high performance 4X (times) beam condenser specially designed for use with the DC-3 Diamond Compression Cell P/N GS02555.

Although the DC-3 diamond compression cell accessory can be used alone for transmission spectral measurement of appropriate sample types that have been compressed between the diamond windows, the microfocus beam condenser reduces a beam of infrared radiant light to focus it through the 1.5mm diameter aperture of the diamond window in the DC-3 accessory and therefore improves the light transmission throughput measurable in use of the DC-3 accessory.

The simple two lens optical system of the microfocus beam condenser allows for a quick and easy alignment for optimum light throughput over a wide working wavelength range. The microfocus beam condenser offered under P/N GS02560 has AR coated ZnSe lenses that allow for a transmission range in the mid IR to circa 600 cm^{-1} , whereas when offered under P/N GS02561, the lenses used are non-AR coated KRS-5 material which allows for an extended range in the mid-infrared to 350 cm^{-1} .

The DC-3 diamond compression cell locates accurately and reproducibly within the microfocus beam condenser using two spring ball catches. A standard Specac Benchmark™ baseplate is used to mount and correctly install the microfocus beam condenser for an optimum stability into the sample compartment of all commercially available FTIR spectrometer systems. A DTGS detector is sufficiently sensitive for use with the combination of the DC-3 when installed into the microfocus beam condenser, although there will be an enhanced sensitivity for spectral measurement if an alternative MCT (liquid nitrogen cooled) detector system is available.

This user instruction manual for the microfocus beam condenser is designed to be used with the instructions for the DC-3 (2I-02555-2).

2. Unpacking and Checklist

On receipt of your accessory please check that the following have been supplied:

- 1 Microfocus beam condenser with ZnSe lenses (GS02560) or with KRS-5 lenses (GS02561) and its user instruction manual.
- 1 Benchmark™ baseplate for spectrometer to be used.
- 1 Benchmark™ baseplate installation guide instruction manual.
- 1 1.5mm Allen key.
- 1 2.0mm Allen key.

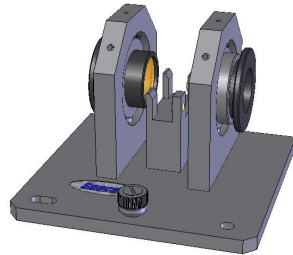

If your microfocus beam condenser accessory was ordered as part of a DC-3 Kit (GS02556 or GS02557) it will also include:

- 1 DC-3 Diamond Compression Cell (GS02555)
- 1 Tool kit consisting of:
 - Sample forceps.
 - Stainless steel sample needle.
 - Knife, blades (10) and blade remover (2).

Carefully remove the microfocus beam condenser accessory and DC-3 diamond compression cell (if ordered as a kit) from their container(s) and packaging and proceed for use of the items by following the information from the user instruction manual(s).

Please take note of the serial number identification of the microfocus beam condenser accessory to include for reference, if ever needing to contact Specac.

3. Warnings for Safe Usage



Please read this section before using Microfocus Beam Condenser and DC-3 Accessories

Important: *The DC-3 accessory is intended for the preparation of small compressible samples. Incorrect use will break the diamond windows. Please note the following points:*

- The DC-3 diamond compression cell is for use with small compressible samples. It is not suitable for crushing large samples such as whole polymer pellets. These should be pre-crushed in a die, or a small fragment should be cut off.
- The DC-3 is a **compression cell**; it is not a diamond anvil cell. It should not be used for crushing or compressing extremely hard samples. Care should be taken that the sample does not contain any hard particles (for example, some sand or grit) that could cause failure and damage to the thin (0.5mm) diamond windows.

Important: *The maximum load that can be applied to a sample will vary depending on the area of the sample and its hardness. This makes it difficult to provide guidelines, but the following points may be helpful:*

- Experiment first with softer samples (for example, polystyrene) to get the “feel” of the product. Learn to judge the minimum size of the sample that will give a “just large enough” compressed area and optimum sample thickness.
- Samples that flow enough to cover a significant area of the window can usually be tightened to full finger tightness.
- Hard samples that do not compress easily to form a thin film need great care. Use the smallest practical quantity of sample and do not apply high loads unless the sample is seen to compress successfully.

Specac Limited cannot accept responsibility for any window breakage howsoever caused.

Chemical Samples

With use of any spectroscopic accessory that involves the study of a wide range of chemical samples, the associated risk in handling may mostly be attributed to the specific sample type to be handled itself. As far as it is possible you should follow a procedure for safe handling and containment of the type of sample to be used.

With respect to safety in operation specifically to the DC-3 diamond compression cell accessory, this uses a diamond (type IIIA) window in each of the upper and lower support plates of the complete assembly where a sample makes contact. However, if the DC-3 is to be used with its compatible microfocus beam condenser accessory, there is a choice of either ZnSe or KRS-5 material for the beam condensing lens assemblies used in this accessory.

Out of these three different crystal material types, KRS-5 and then ZnSe are the most potentially hazardous materials with respect to a toxicity risk in use and handling. Diamond can be considered relatively safe to use, although the general rule when working with **any** crystal material (and sample) is to always wear gloves and safety gear (e.g. safety spectacles) when handling to obviate the risk of contact with the skin. Specifically in operation of the DC-3 diamond compression cell accessory there is a minimal risk associated with the diamond material itself for actual sampling contact. Similarly, there is minimal risk of contact with the KRS-5 or ZnSe materials used for the lens assemblies within the microfocus beam condenser (if this is to be used) as these crystal materials are safely contained within the beam condenser optical unit lens housings and should not require being handled after an initial alignment and optimum throughput has been obtained at installation.

Crystal material safety data sheet information for each of the material types can be consulted for safe handling. A copy of each of these datasheets can be found in this instruction manual in the **Notes on Cleaning** Section found on pages 18 to 22.

4. Using the Microfocus Beam Condenser

General Principles

The microfocus beam condenser (1) has been designed to specifically accommodate the DC-3 diamond compression cell accessory and the two items are used in conjunction with each other when installed into the sample compartment of an FTIR spectrometer system. It does not matter if the IR light of the spectrometer from the source to the detector is a left to right or right to left beam direction as it passes through the sample compartment for compatibility of use. The optics (lenses) of the microfocus beam condenser with installation of the DC-3 constitute a symmetrical arrangement, but for alignment purposes to optimise the light throughput, the output lens will need to be adjusted first so the beam passage direction for the spectrometer is required to be known.

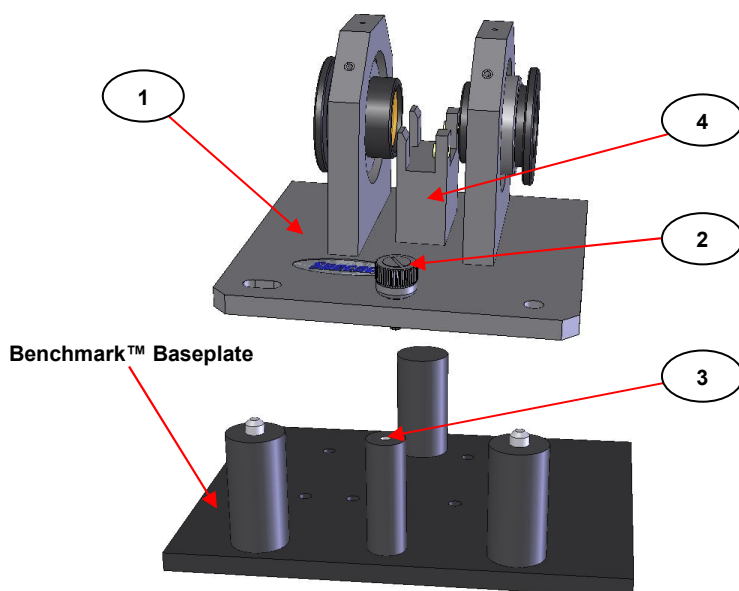

Fig 1. Microfocus Beam Condenser for Attachment to the Benchmark™ Baseplate

Benchmark Baseplate Installation

The microfocus beam condenser (1) itself is installed into the sample compartment of a spectrometer via use of the Benchmark™ type of mounting baseplate. The microfocus beam condenser is attached to the Benchmark™ baseplate via a front thumbscrew (2) fixing into the front central support post (3) of the Benchmark™ baseplate. The fixing slot and round hole at the front of the microfocus beam condenser align with the pin studs on the other two support posts at the front of the Benchmark™ baseplate and the thumb screw (2) is pushed down and turned clockwise to securely attach the accessory to the baseplate. (See Fig 1.)

On receipt of the microfocus beam condenser accessory alone or as part of the DC-3 Kit, a particular Benchmark™ baseplate will be provided that is suitable for use in the spectrometer system. Please consult the Benchmark™ baseplate installation guide provided to instruct how the Benchmark™ baseplate is correctly installed into the spectrometer sample compartment, prior to fixing of the microfocus beam condenser to baseplate as shown in Fig 1.

Fitting of DC-3 into the Microfocus Beam Condenser

The DC-3 diamond compression cell accessory fits into the central sample support block (4) of the microfocus beam condenser (1). There are two ball spring catches (5) in the support block (4) that locate with the two grooves (6) that have been milled into the outer surface of the lower support plate (7) of the DC-3 accessory. (See Figs 2. and 3.)

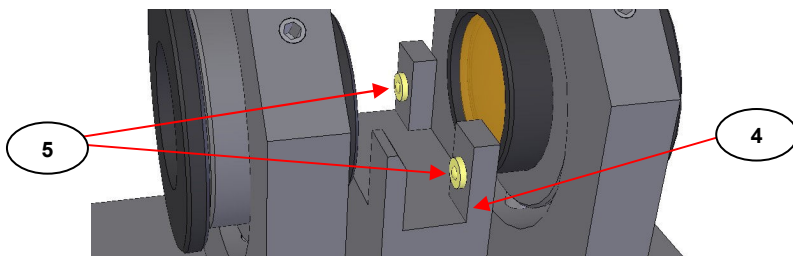

Fig 2. Sample Support Plate and Ball Spring Catches of the Microfocus Beam Condenser

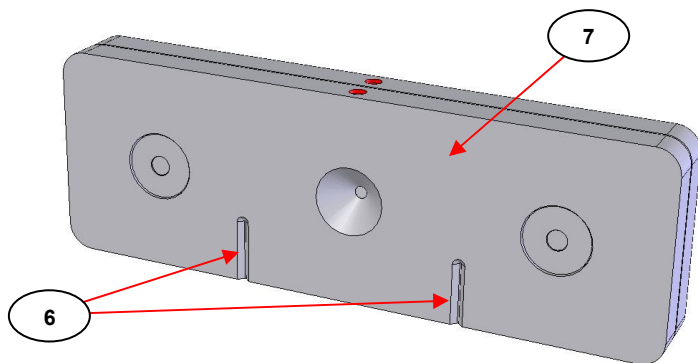

Fig 3. Location Grooves on the Lower Support Plate Outer Surface of the DC-3 Accessory

From consultation of the user instruction manual for the DC-3 and having constructed the DC-3 accessory with or without an appropriately compressed sample (without for background reference spectrum), carefully place the DC-3 correctly into the sample support block (4), such that the two location grooves (6) align with the two ball spring catches (5) and push the DC-3 assembly all the way down into the support block (4) so that the lower edge of the DC-3 assembly is in contact, flush and parallel with the top surface of the support block (4). (The DC-3 accessory will only fit one way correctly into the microfocus beam condenser). (See **Fig 4.**)

With the DC-3 positioned correctly in the support block (4) of the microfocus beam condenser (1) the diamond windows of the DC-3 will be positioned correctly for projection of a 4 times beam condensed focal spot of light to pass centrally through the DC-3 accessory towards the detector of the spectrometer system.

Note: *The ball spring catches (5) and their maximum compression from location with the grooves (6) indirectly determine an overall thickness of sample that can be accommodated between the DC-3 diamond windows. If the sample is too thick then the overall thickness of the assembly cannot be pushed into position for a correct mounting within the sample support block (4).*

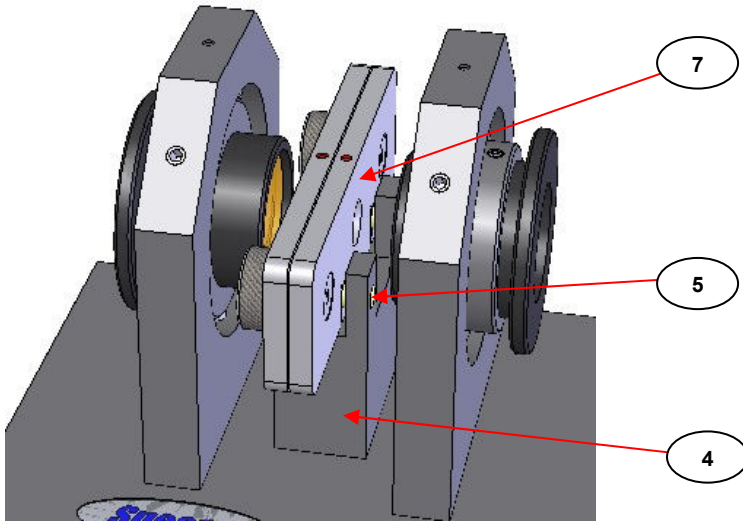

Fig 4. DC-3 Correctly Fitted Into Microfocus Beam Condenser

When using the DC-3 accessory with the microfocus beam condenser the maximum thickness of a sample that can be accommodated before any compression of the sample may take place is nominally 250 microns.

Alignment (Light Throughput Optimisation)

For optimisation of the light throughput of the microfocus beam condenser (1) the two lenses (8) need to be aligned correctly for passage of the light through the DC-3 accessory. The alignment procedure should be carried out with the DC-3 accessory correctly installed into the support block (4) but **without any sample** compressed between the two diamond windows - the condition for collection of a reference background spectrum for the DC-3.

Typically when the DC3 accessory is constructed for collection of a reference background spectrum and is placed within a well aligned microfocus beam condenser, the following percentage levels of optical light throughput compared to an unobstructed beam at 100% should be achievable.

For the DC-3 P/N GS02555 in a **ZnSe lens** Microfocus Beam Condenser P/N GS02560, throughput level is between 5 to 7%.

For the DC-3 P/N GS02555 in a **KRS-5 lens** Microfocus Beam Condenser P/N GS02561, throughput level is between 3 to 4%

For a correct alignment procedure it is important to know the IR light beam direction through the sample compartment from the source to the detector of the spectrometer. It will be either a left to right (**L to R**) or right to left (**R to L**) beam direction as viewed from above or the front of the spectrometer and this determines the input and output lens (**8**) of the microfocus beam condenser. For the purpose of these instructions relating to the images, an **R to L** beam direction has been chosen.

Focusing of the Lenses

To optimize the light throughput of the microfocus beam condenser with the DC-3 accessory installed, both the input and output lenses (**8**) need to be focused accordingly.

There are two modes of adjustment for correct focusing of the lens (**8**) material within its lens housing (**9**).

1. Concentricity of lens (**8**) with diamond window aperture in DC-3 – concentric movement of lens housing (**9**) within its ring mount (**10**).
2. Focal Length – lateral movement (in and out) of the lens (**8**) in the lens housing (**9**) within its ring mount (**10**).

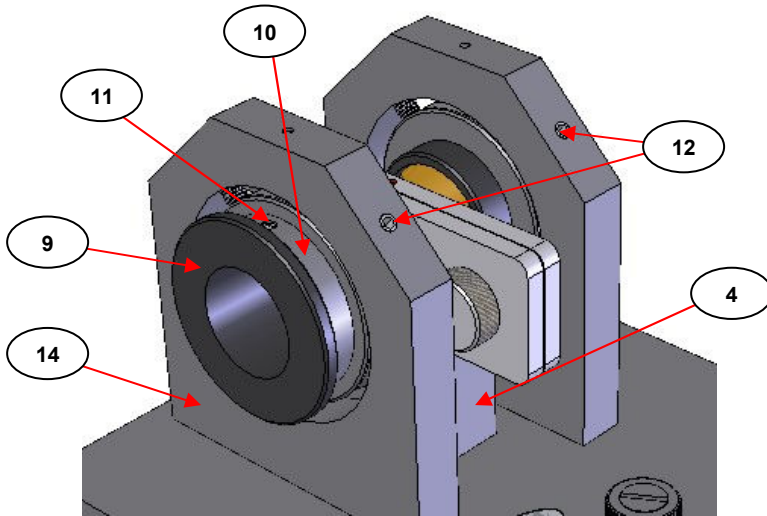

Fig 5. Output Lens for R to L Beam Spectrometers

When supplied from Specac as new, the microfocus beam condenser (1) will have been pre-aligned using a laser light system to give an initial detectable throughput when the accessory has been installed into the spectrometer via mounting on the Benchmark™ baseplate.

From **Fig 5**, it can be seen that the lens housing (9) is held within in a circular ring mount (10). Within the ring mount (10) there is a locking grub screw (11) that holds the lens housing (9) in position within the ring mount (10) when the focal length position of the lens material (8) has been established for an optimum throughput.

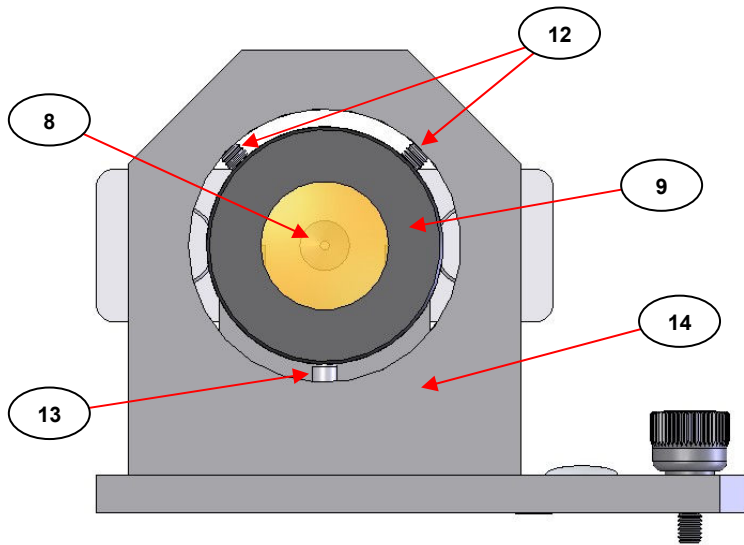

Fig 6. Output Lens for R to L Beam Spectrometers (End-on View)

From **Fig 6.** which is an alternative end-on view of the output lens assembly of parts, although the lens housing (9) is obscuring a view of the ring mount (10) it can be seen that this complete assembly is adjusted for concentricity of the lens material (8) with the DC-3 diamond window aperture by adjustment of the two grub screws (12). The two grub screws (12) affect the concentric position of the ring mount (10) part which is supported on a spring loaded stud (13) at the base of the overall support frame (14). As either one of the two grub screws (12) is loosened or tightened the concentricity of the lens (8) and lens housing (9) assembly is affected by the overall movement of the ring mount (10) allowed from the spring loaded stud (13).

Note: *This arrangement of parts (8, 9 and 10) for operation and adjustment to the **output lens** assembly is exactly the same as the **input lens** assembly.*

The ring mount (10) part itself can rotate within the support frame (14) as it is held between the two grub screws (12) and the spring stud (13). Therefore it is **an important requirement before any alignment procedure is started** to ensure that the locking grub screw (11) within the ring mount (10) is orientated to a 12 O'clock position as shown in **Fig 5**. for both output and input lens assemblies to act as a **reference point** for the concentric adjustment setting of the lens (8) and lens housing (9) and the focal length position of the lens (8) material. For correct 12 O'clock positioning of the grub screw (11) it is a simple matter of loosening the two grub screws (12) to slacken off the spring force of the spring stud (13) and rotating the ring mount (10) within the support frame (14), with the lens housing (9) part already locked into position via the grub screw (11) having been tightened. When the grub screw (11) has been positioned correctly the two grub screws (12) can then be retightened to hold the ring mount (10) more securely and concentrically within the support frame (14), prior to the alignment procedure.

Alignment Procedure

With the Benchmark™ baseplate installed, establish an IR beam energy reading signal throughput value to monitor on your spectrometer system **without** the microfocus beam condenser and DC-3 accessory installed on the baseplate. This will give a theoretical 100% throughput value for your system.

Now install the microfocus beam condenser with the DC-3 accessory already installed correctly into the support block (4) onto the Benchmark™ baseplate and secure the complete assembly of parts together via the thumb screw fixing (2).

There should now be a reduced energy level of light throughput registering at the spectrometers detector system from installation of the component parts that are in initial rough alignment, but the fine alignment procedure starts with the **output** lens (8) and lens housing (9) assembly to ensure that it is concentric to the diamond window aperture of the DC-3 accessory.

Output Lens Adjustment

Whilst monitoring the energy level of throughput adjust the two grub screws (12) by turning them clockwise or anticlockwise using the 2mm Allen key provided to influence the overall concentricity alignment of the lens (8) within the lens housing (9) for the 1.5mm diameter aperture of the diamond windows in the DC-3 accessory. Carry out the grub screw (12) adjustment until an optimum energy throughput level has been obtained.

Now adjust the focal length of the **output** lens (8) by loosening the locking grub screw (11) and very gently slide the lens housing (9) assembly in or out of the ring mount (10) in a lateral movement.

Note: *It is important to move the lens housing (9) laterally and smoothly within the ring mount (10) **without rotation** of the lens housing assembly (9) if possible. The previous alignment stage for concentric placement of the lens (8) has obviated the need for any rotational positioning of the lens (8) itself to optimize the energy throughput in the alignment procedure.*

When an optimum energy throughput has been obtained from lateral adjustment of the lens housing (9) for the correct lens (8) focal length, the grub screw (11) is tightened to lock the lens housing (9) into position in the ring mount (10).

Input Lens Adjustment

When an optimum energy level has been achieved from alignment of the **output** lens (8), repeat the concentric positioning and focal length adjustments for the **input** lens assembly of parts (8, 9 and 10).

If the energy level increases significantly after fine alignment and positional fixing of the input lens (8) for a passage of light through to the DC-3 accessory diamond windows, then it may be necessary to return to the output lens (8) side again for concentric realignment and focal length positioning for fine tuning of the light beam to be directed towards the detector.

When an optimum energy throughput has been achieved for the microfocus beam condenser with DC-3 accessory in position the accessory is ready to use for sampling. Follow the instructions for mounting and compression of a sample itself within the DC-3 accessory from its own user instruction manual.

Change of Detector

If for any sampling measurement the detector is changed from a room temperature DTGS device to a liquid nitrogen cooled MCT version, some re-alignment, due to the more critical focusing on to the smaller MCT detector element, may be required.

Following the alignment procedure **for just the output lens (8) only** concentric position and focal length adjustment may be all that is required to provide an optimum throughput energy measurement when changing for use of a different detector.

Notes on Cleaning

When cleaning the diamond windows of the DC-3 diamond compression cell in preparation for a new sample, it is **very important to take care** to avoid damage to the crystal material. As mentioned in the Warnings For Safe Usage information (Section 3, page 6), diamond crystal material that is used for sample contact is not particularly hazardous in terms of a risk of toxicity if it comes into contact with the skin. There is more risk associated with the ZnSe and most especially the KRS-5 lens materials in the microfocus beam condenser accessory, should there be a need to clean these items.

Note: *Always wear gloves to protect yourself and the crystal material from cleaning and when sample handling.*

From the design and size of the DC-3 accessory, a useful feature is the capability for easy installation and removal from a microscope system or the microfocus beam condenser accessory if being used, such that any sample can be prepared remotely and safely within the DC-3 accessory and then can be bought back for fitting into the

microscope or microfocus beam condenser whilst installed in the spectrometer. Similarly for cleaning, it is necessary to remove the DC-3 accessory from the working area and carry it to a safe area for solvent cleaning and wiping with a tissue and therefore minimise any risk of contamination being carried over to other equipment or components of the accessory whilst in situ.

Solvents such as water, methanol and acetone are suitable to use for cleaning purposes on the diamond windows and ZnSe and KRS-5 lenses, if these lenses do require cleaning. Some sample stains or residues if present on or around the diamond window area of the DC-3 accessory may require removal using a strong acid or base solution, but if these types of cleaning solvents are employed, do so using sparingly. Quickly clean away any excess solvent using a cloth or tissue and follow by rinsing away with further water to dilute any effect of an acid or base that may remain.

When wiping away any solid or liquid sample, or marks and blemishes on the lenses, it is advisable to use soft lens tissues to avoid scratches being caused on the surface of the crystal material. Ordinarily, diamond material being extremely resilient will be unaffected from this treatment, but any scratches and blemishes if introduced to a crystal surface will result in poor light throughput for the technique and an overall degradation in the accessories performance.

In common and general usage it will only be necessary to wipe and clean away at the diamond window surface of the DC-3 accessory that comes into contact with a sample. If possible try to avoid any solvent or cleaning solution materials from getting to the conical aperture surface sides of the upper and lower support plates. There is a risk that any dried solution residues that have been introduced in this way to this surface of the diamond window could be seen as an "impurity" in any "background" spectrum to be collected, and so this contaminant would need to be removed before any further sampling can continue.

Data Sheet For Diamond

General

Hardest substance known for carbon (C) elemental form.

Can be shaped, cut and polished to form spectral transmission window or crystal for ATR spectroscopy.

Has a highish Refractive Index value and can suffer reflection losses but these can be improved with antireflection optical coatings

Extremely chemically resistant to practically all known materials.

Element symbol: C

Chemical Abstracts Service (CAS) No: 7440-44-0 (Synthetic) : 7782-42-5 (Natural)

Physical Data

Appearance: Clear, transparent and generally colourless solid. Has no odour.

Melting point: N/A.

Boiling point: 4827°C.

Vapour pressure: N/A.

Specific gravity: 2.26 g cm⁻³.

Solubility in water: Insoluble

Hardness: 5700 Kg/mm².

Refractive Index: 2.43 (at 2000cm⁻¹ - wavenumbers).

Spectroscopic transmission range: 40,000 to 10 cm⁻¹ (wavenumbers).

Stability

Stable.

Toxicology

Not classified as a dangerous or harmful material according to EC directives.

Personal Protection

Always wear safety spectacles and gloves when handling the window or crystal material.

Allow for adequate ventilation.

Storage

Keep windows or crystal stored in a cool, dry container.

Data Sheet For Zinc Selenide

General

Toxic and hard, yellow coloured crystalline powder when fused together as a solid can be used as a transmission window material or as a crystal material for attenuated total reflectance (ATR) FTIR spectroscopy.

Insoluble in water, but attacked by strong acids and bases. (pH range 4 to 11 tolerant). Organic solvents have no effect.

Fairly brittle as a window material and sensitive to thermal and mechanical shock.

Molecular formula: ZnSe

Chemical Abstracts Service (CAS) No: 1315-09-9.

Physical Data

Appearance: Yellow crystals, granular powder or amber coloured window material.

Melting point: 1515°C at 1.8 atmospheres. (26.5psi)

Solubility in water: 0g/100g at 0°C.

Hardness: 120 Kg/mm².

Refractive Index: 2.43 (at 2000cm⁻¹ - wavenumbers).

Spectroscopic transmission range: 20,000 to 500 cm⁻¹ (wavenumbers).

Stability

Stable. Reacts with acids to give highly toxic hydrogen selenide. May be air and moisture sensitive. Incompatible with strong acids, strong bases and strong oxidising agents.

Toxicology



Toxic if small amounts are inhaled or swallowed. In stomach toxic hydrogen selenide (H₂Se) is liberated. Skin and eye irritant. Danger of cumulative effects from frequent handling without protection.

Personal Protection

Always wear safety spectacles and gloves when handling the powder or window material. Allow for good ventilation.

Storage

Keep powder or windows stored in a cool, dry container, with appropriate safety labeling.

Data Sheet For KRS-5

General

Synonyms: Mixture of Thallium Bromide and Thallium Iodide (typically 58% iodide content). Very toxic red coloured soft crystalline powder when fused together as a solid can be used as a transmission window material or as a crystal material for attenuated total reflectance (ATR) FTIR spectroscopy.

Slightly soluble in water, soluble in bases, but not soluble in acids. Not hygroscopic. Organic solvents have no effect.

Soft window material and easily deformed.

Molecular formula: $TlBr_{0.4}I_{0.6}$

Physical Data

Appearance: Red, soft crystals, granular powder or red coloured window material

Melting point: 414°C

Solubility in water: 36g/100g at 0°C.

Hardness: 40 Kg/mm².

Refractive Index: 2.38 (at 2000cm⁻¹ - wavenumbers).

Spectroscopic transmission range: 17,000 to 250 cm⁻¹ (wavenumbers).

Stability

Stable.

Toxicology



Very toxic if small amounts are inhaled or swallowed. May be fatal if swallowed. May be absorbed through the skin. Irritant.

Personal Protection

Always wear safety spectacles and gloves when handling the powder or window material.

Allow for good ventilation. If material is machined, polished or ground, precautions must be taken against inhalation of dust.

Storage

Keep powder or windows stored in a cool, dry container, with appropriate safety labeling.

5. Changing Lenses in the Microfocus Beam Condenser

The microfocus beam condenser can be supplied as P/N GS02560 fitted as standard with ZnSe lenses, or as P/N GS02561 fitted as standard with KRS-5 lenses.

If the lenses ever become damaged or unusable, or if it is wished to have a spare set of alternative lenses to use in the microfocus beam condenser, the appropriate spare lens sets can be provided for a replacement fit by the user from the following part numbers:

P/N GS20570 KRS-5 lens (8) in lens housing (9) assembly for the microfocus beam condenser (pair).

P/N GS20571 ZnSe lens (8) in lens housing (9) assembly for the microfocus beam condenser (pair).

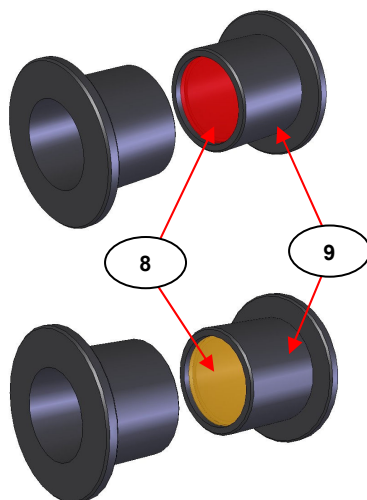

To change a lens assembly within the microfocus beam condenser the grub screw (11) is loosened (see Fig 5.) and the existing whole lens housing (9) part is pulled out and away from the ring mount (10). Fitting of the new lens assembly is a reverse procedure. Always wear gloves when changing the lens assemblies to protect yourself and to minimise the risk of damage to the lens (8) surface from handling.

Note: *It will be necessary to carry out a re-alignment procedure to optimize the energy throughput with any change of lenses.*

6. Spare Parts - Microfocus Beam Condenser

GS02555 DC-3 Diamond Compression Cell

GS02556 DC-3 Diamond Compression Cell Kit – includes:
GS02555 DC-3 Diamond Compression Cell
GS02560 Microfocus Beam Condenser with ZnSe lenses,
Benchmark™ baseplate, forceps, stainless steel sample
needle, sample preparation knife, blades (10) and blade
remover (2).

GS02557 DC-3 Diamond Compression Cell Kit – includes:
GS02555 DC-3 Diamond Compression Cell
GS02561 Microfocus Beam Condenser with KRS-5 lenses,
Benchmark™ baseplate, forceps, stainless steel sample
needle, sample preparation knife, blades (10) and blade
remover (2).

GS02560 Microfocus beam condenser with ZnSe lenses.

GS02561 Microfocus beam condenser with KRS-5 lenses.

GS02570 Microfocus beam condenser KRS-5 lens kit.

GS02571 Microfocus beam condenser ZnSe lens kit.

7. Legend – Bubble Part Number Identification

- (1) Microfocus beam condenser accessory.
- (2) Fixing thumb screw.
- (3) Central front post of Benchmark™ baseplate.
- (4) Sample support block.
- (5) Spring ball catch.
- (6) Location groove on DC-3 accessory.
- (7) Lower support plate of DC-3 accessory.
- (8) Lens material (ZnSe or KRS-5).
- (9) Lens housing.
- (10) Support ring mount.
- (11) Locking grub screw of lens housing.
- (12) Adjustment grub screw for lens concentricity.
- (13) Spring loaded stud.
- (14) Overall support frame for lens assembly.

Worldwide Distribution

France

Eurolabo - Paris.
Tel.01 42 08 01 28
Fax 01 42 08 13 65
email: contact@eurolabo.fr

Germany

L.O.T. - Oriel GmbH & Co,
KG - Darmstadt
Tel: 06151 88060
Fax: 06151 880689
email:info@LOT-Oriel.de
Website: www.LOT-Oriel.com/de

Japan

Systems Engineering Inc. -Tokyo
Tel: 03 3946 4993
Fax: 03 3946 4983
email:systems-eng@systems-eng.co.jp
Website: www.systems-eng.co.jp

Spain

Teknokroma S.Coop C. Ltda
Barcelona
Tel: 93 674 8800
Fax: 93 675 2405
email: comercial@teknokroma.es

Switzerland

Portmann InstrumentsAG
Biel-Benken
Tel: 061 726 6555
Fax: 061 726 6550
email: info@portmann-instruments.ch
Website:www.portmann-instruments.ch

USA

SPECAC INC.
414 Commerce Drive
Suite 175,
Fort Washington,
PA 19034, USA
Tel: 215 793 4044
Fax: 215 793 4011

United Kingdom

Specac Ltd. - London
River House, 97 Cray Avenue,
Orpington
Kent BR5 4HE
Tel: +44 (0) 1689 873134
Fax: +44 (0) 1689 878527
Registered No. 1008689 England

Brilliant Spectroscopy™

www.specac.com

SPECAC INC.

414 Commerce Drive
Suite 175,
Fort Washington,
PA 19034, USA
Tel: 215 793 4044
Fax: 215 793 4011

SPECAC LTD.

River House, 97 Cray Avenue,
Orpington
Kent BR5 4HE
Tel: +44 (0) 1689 873134
Fax: +44 (0) 1689 878527
Registered No. 1008689 England